

Honeyville

**Bucket
Elevators**



Galvanized For Long Life **and Low Maintenance**

7 Sizes – Capacities from 1,350 to 18,000 BPH



HONEYVILLE SERIES BUCKET ELEVATORS

Honeyville Bucket Elevators feature heavy-duty components, jig welded for easy assembly. All pieces are galvanized for a durable finish and long, maintenance free life.

The Honeyville design provides the ideal grain discharge for the least wear based on the rated capacities.

1. **HEAD** – Heavy-duty galvanized steel construction designed for clean discharge.
2. **HEAD COVER** – Sectioned and hinged for easy service of internal components.
3. **SHAFT MOUNTED** – Gear reducer, easily adjustable torque arm. Quality belts and drive sheaves.
4. **HEAD PULLEY** – Crowned and fitted with taper-lock bushings, non-slip rough top lagging for maximum traction. (Slide lagging is optional)
5. **BEARINGS** - High quality, heavy duty bearings, easy maintenance for longer life.
6. **BELT** – High strength PVC belt for minimal stretch, impregnated solid carcass, pre-punched for easy bucket mounting. (SOR Rubber belt available)
7. **BUCKETS** - High Quality Polyethylene CC Deep Terminal design. (Steel buckets optional)
8. **TRUNKING** - Twin box construction. Heavy gauge ASTM A-526 G90 galvanized steel Double seam, jig welded for perfect alignment. Inspection sections feature easy access to belt and buckets through inspection doors.
9. **BOOT** - Heavy gauge galvanized steel. Easy to adjust take-ups for boot pulley. High or low, standard or expanded width hopper. Hand slide clean-out gates provided on both sides.

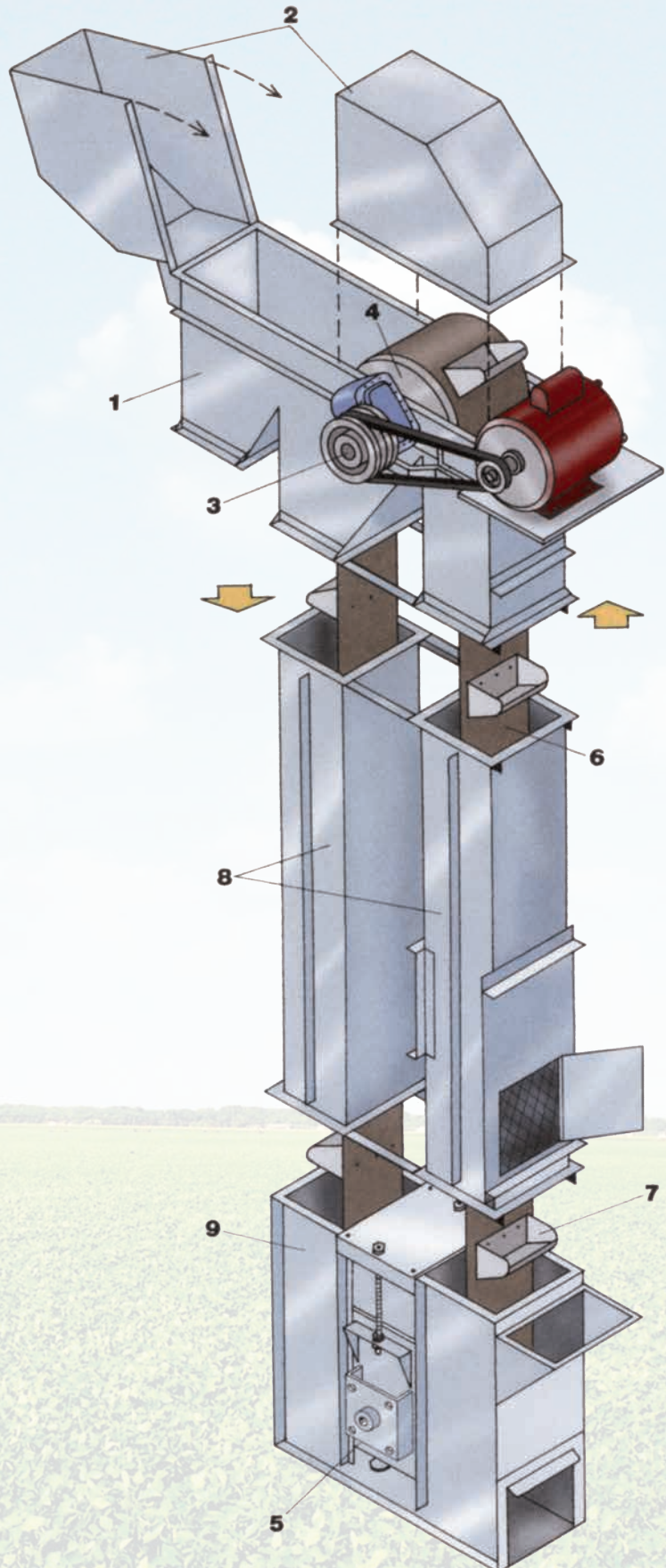

MODEL:	34-14	38-20	43-24	48-30	54-36	60-36	66-42
Standard Capacity Range in BPH	1,350 to 1,550	1,900 to 2,250	3,200 to 3,750	4,600 to 5,750	5,700 to 8,000	9,300 to 13,000	14,250 to 18,000
Head & Boot Pulley Dia.	14"	20"	24"	30"	36"	36"	42"
Head Section Steel ♦	14 Ga.	12 Ga.	12 Ga.	10 Ga.	10 Ga.	10 Ga.	3/16"
Boot Section Steel ♦	12 Ga.	10 Ga.	10 Ga.	3/16"	3/16"	3/16"	1/4"
Standard Bucket Size	6" x 4"	7" x 5"	9" x 5"	10" x 6"	12" x 6"	16" x 7"	18" x 8"
Trunking Steel * ♦	16 Ga.	14 Ga.	14 Ga.	14 Ga.	14 Ga.	14 Ga.	12 Ga.
A	40-1/4"	54-1/2"	61-1/4"	75-1/4"	88-1/2"	92-1/2"	110"
B	35-1/2"	50-3/4"	56-3/8"	70-1/2"	74-1/2"	74-1/2"	95-5/8"
C	38"	53-1/4"	58-7/8"	73"	80"	80"	95-5/8"
D	120"	120"	120"	120"	120"	120"	120"
E	120" or 60"	120" or 60"	120" or 60"	120" or 60"	120" or 60"	120" or 60"	120"
F	28-1/4"	37-1/8"	43-1/8"	49-1/8"	55-1/8"	59-1/8"	68-1/4"
G (Trunking Dimension)	7-1/2" x 10"	9" x 11"	10" x 12"	10" x 14"	10" x 16"	12" x 20"	14" x 26"
H-High Hopper (standard)	32-1/2"	36-1/2"	41-1/2"	47"	56-1/2"	56-1/2"	66"
H-Low Hopper (optional)	24-3/8"	26-5/8"	27-7/8"	35-1/2"	41-7/8"	42-1/4"	44-1/2"
I	13"	18-7/8"	22-7/8"	28-7/8"	34-7/8"	34-7/8"	39-3/4"
J	6"	10"	12"	14"	16"	15"	16"

♦ Heavier gauge of steel available on all sizes upon request

* When more than 80' of trunking, the lower portion increases to the next heavier gauge

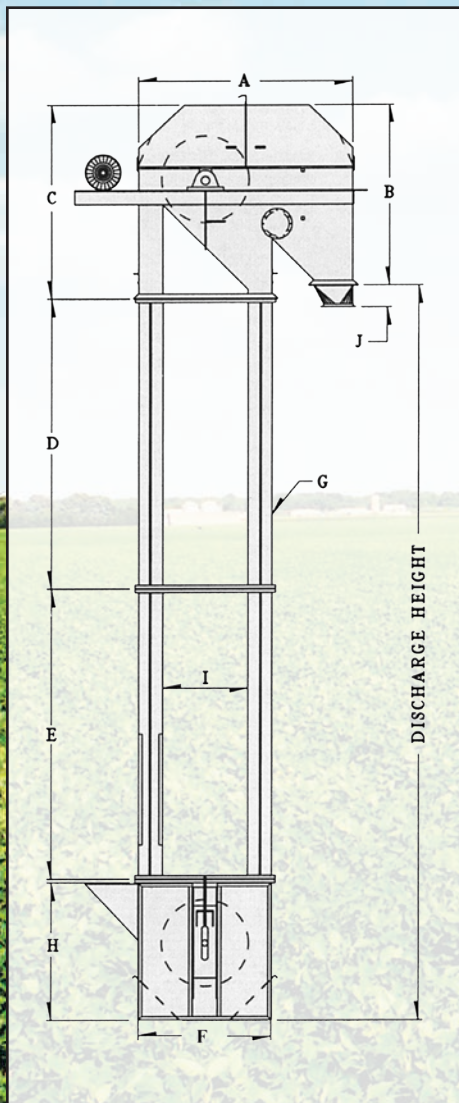

INSPECTION DOOR
No tools needed for door access.

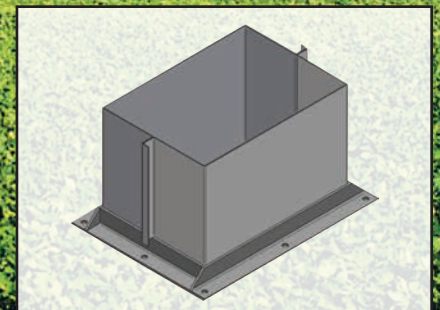

TRUNKING - Honeyville's unique design utilizes ten 90° bends for greater vertical strength and structural integrity.



HONEYVILLE METAL INC.

Honeyville Metal Inc. manufactures a complete line of commercial and agricultural galvanized bucket elevators, pit type incline drag conveyors, horizontal drag conveyors, manual and electronic controlled distributors, u-trough screw conveyors, conveyor supports and towers with related accessories. Honeyville Metal equipment is being used throughout the United States as well as in parts of Canada, South America, Asia, and Europe.

Honeyville Metal began in 1951 in a rural area near Topeka, Indiana. Over the years our facilities have grown steadily and we now have over 191,000 sq. ft. of office, warehouse, and manufacturing area. Our manufacturing facility includes a CNC laser cutter, CNC plasma cutter, turret punches, press brakes, shears and rolls. As we've grown our top priority has remained the same, producing high quality products at competitive prices.

Gently Moving Nature's Grains

Manufactured by



4200S 900W • Topeka, IN 46571
Phone (800) 593-8377 • Fax (260) 593-2486
www.honeyvillemetal.com